

8 7 6 5 4 3 2 1

D  
C  
B  
A

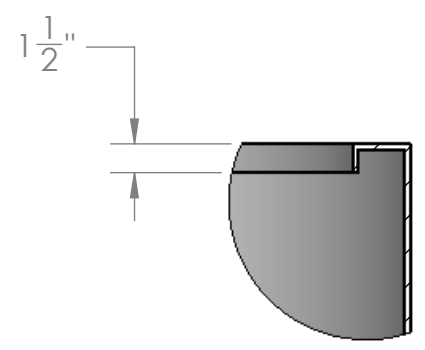

DETAIL A  
SCALE 1 : 10

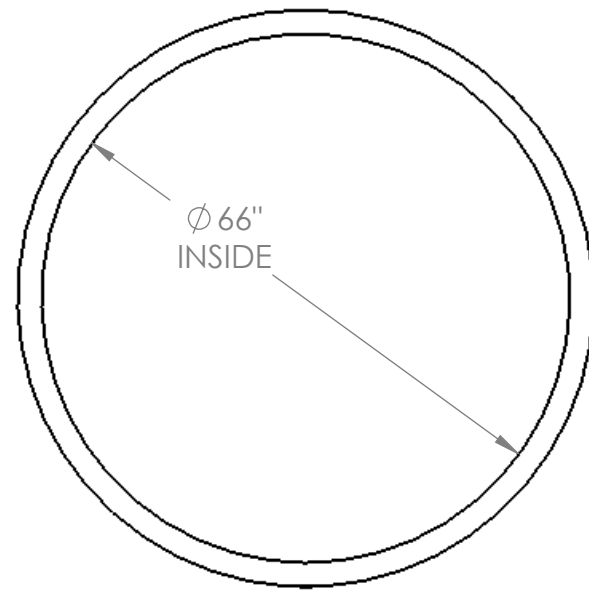
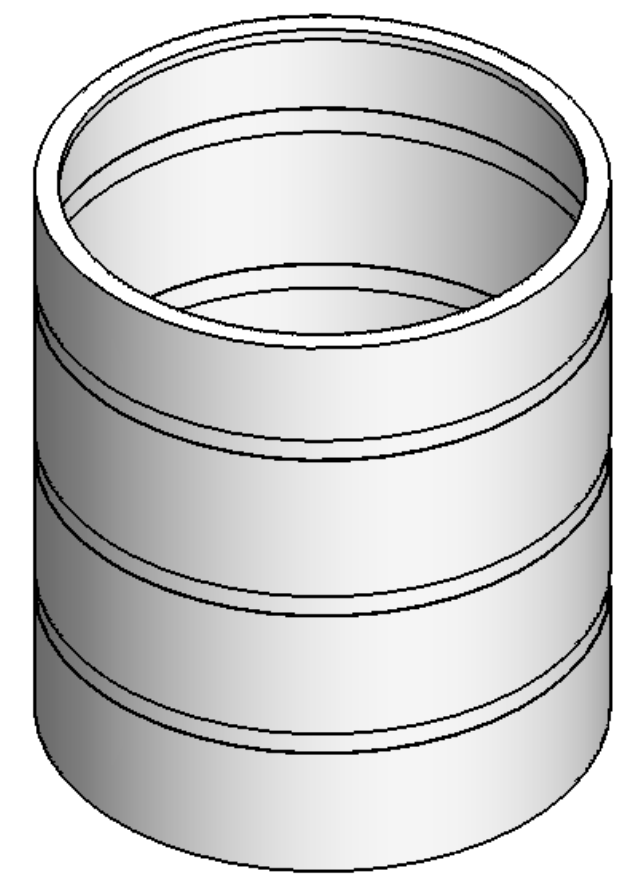

- NOTES:
1. MATERIAL: HDPE
  2. MOLDED WEIGHT: 270 LBS.
  3. RATED: 1.5 S.G.

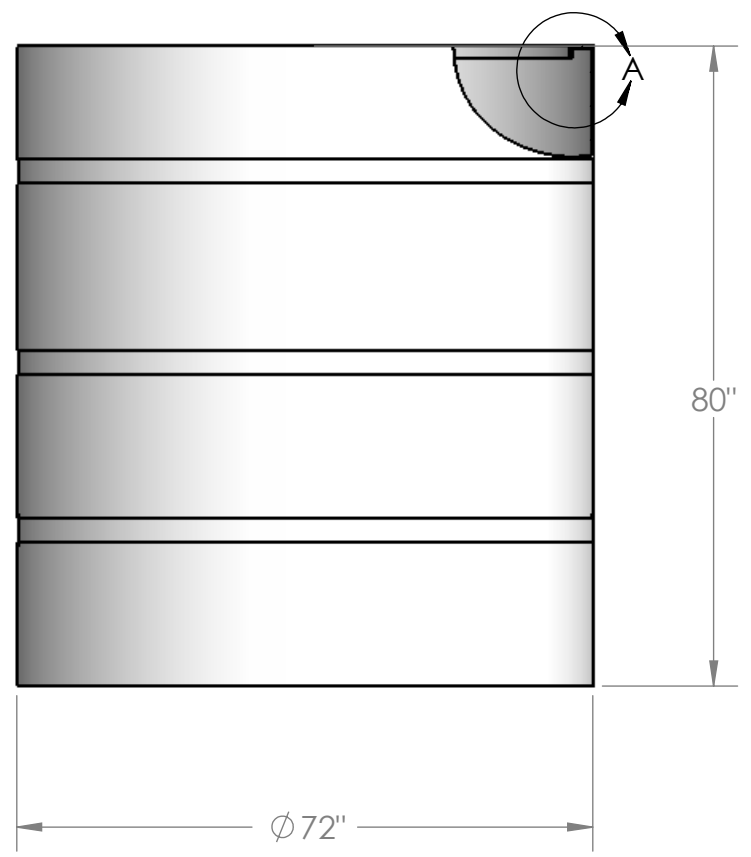

**PROPRIETARY AND CONFIDENTIAL**  
 THE INFORMATION CONTAINED IN THIS DRAWING IS THE SOLE PROPERTY OF <INSERT COMPANY NAME HERE>. ANY REPRODUCTION IN PART OR AS A WHOLE WITHOUT THE WRITTEN PERMISSION OF <INSERT COMPANY NAME HERE> IS PROHIBITED.

		UNLESS OTHERWISE SPECIFIED:		NAME	DATE	CUSTOM ROTO-MOLDING, INC.	
		DIMENSIONS ARE IN INCHES		DRAWN	EBW	1-14-11	TITLE: <b>1325 GALLON OPEN TOP TANK</b>
		TOLERANCES:		CHECKED			
		FRACTIONAL ±		ENG APPR.			
		ANGULAR: MACH ± BEND ±		MFG APPR.			
		TWO PLACE DECIMAL ±		Q.A.			SIZE DWG. NO. REV
		THREE PLACE DECIMAL ±		COMMENTS:			<b>B</b> 1325 OTT
		INTERPRET GEOMETRIC TOLERANCING PER:					SCALE: 1:32 WEIGHT: SHEET 1 OF 1
		MATERIAL					
		FINISH					
NEXT ASSY	USED ON	DO NOT SCALE DRAWING					
APPLICATION							

8 7 6 5 4 3 2 1