

8 7 6 5 4 3 2 1

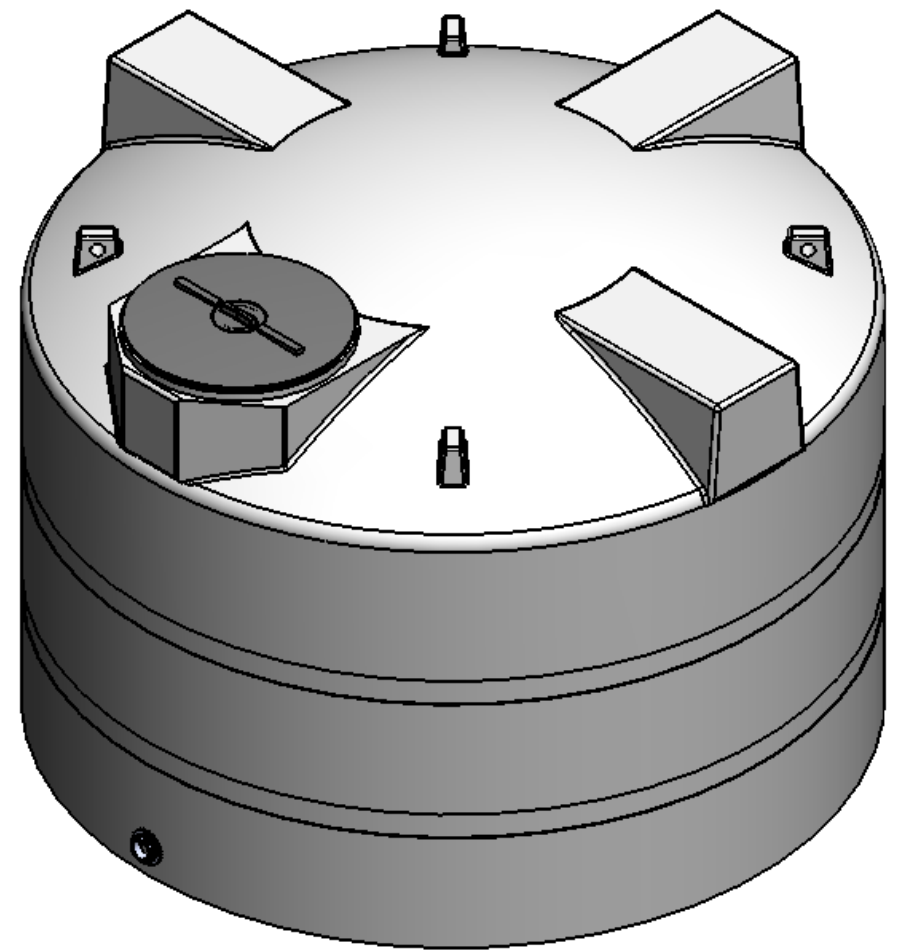
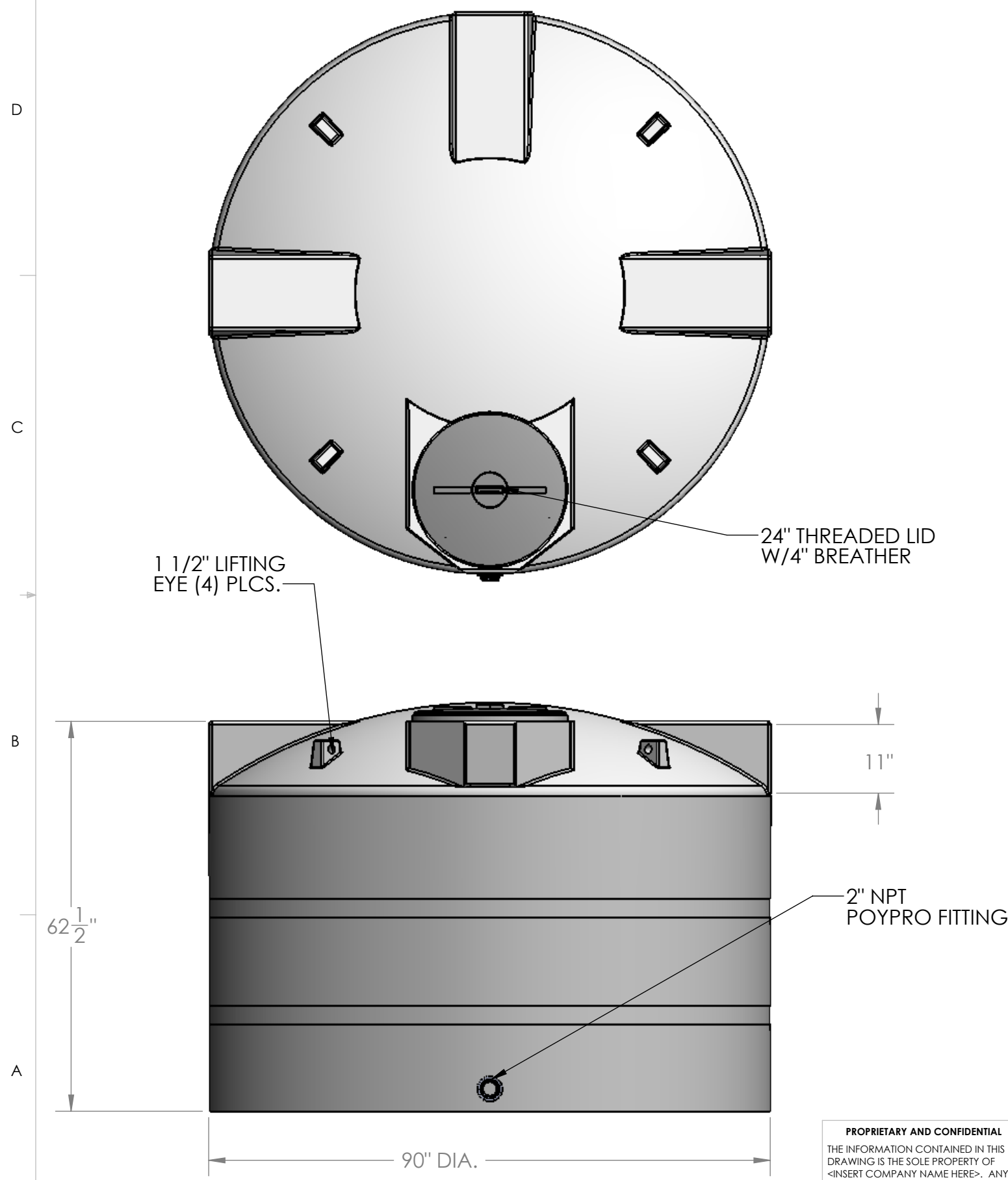

- NOTES:
1. MATERIAL: HDPE
 2. WEIGHT: 240 LBS STD. RATED 1.5 SG.
340 LBS HD. RATED 1.9 SG.

PROPRIETARY AND CONFIDENTIAL
 THE INFORMATION CONTAINED IN THIS DRAWING IS THE SOLE PROPERTY OF <INSERT COMPANY NAME HERE>. ANY REPRODUCTION IN PART OR AS A WHOLE WITHOUT THE WRITTEN PERMISSION OF <INSERT COMPANY NAME HERE> IS PROHIBITED.

		UNLESS OTHERWISE SPECIFIED:		NAME	DATE	CUSTOM ROTO-MOLDING, INC.
		DIMENSIONS ARE IN INCHES TOLERANCES: FRACTIONAL ± ANGULAR: MACH ± BEND ± TWO PLACE DECIMAL ± THREE PLACE DECIMAL ±		DRAWN	EBW	
		INTERPRET GEOMETRIC TOLERANCING PER:		CHECKED		TITLE:
		MATERIAL		ENG APPR.		1600 GALLON VERTICAL TANK
		FINISH		MFG APPR.		
NEXT ASSY	USED ON	DO NOT SCALE DRAWING		Q.A.		DWG. NO.
APPLICATION				COMMENTS:		1600 VT.
						REV
						SCALE: 1:32
						WEIGHT:
						SHEET 1 OF 1

8 7 6 5 4 3 2 1