

8 7 6 5 4 3 2 1

D  
C  
B  
A

D  
C  
B  
A

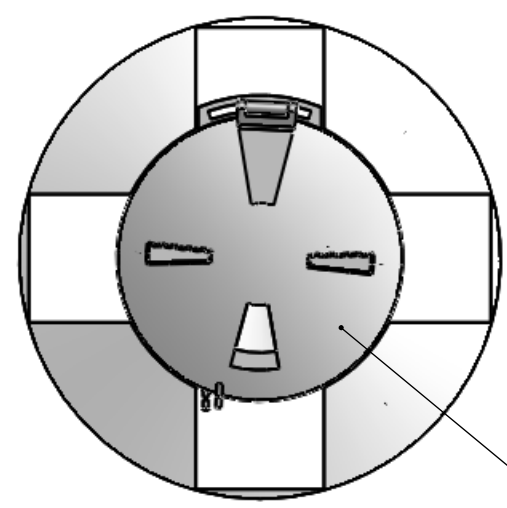

16" NON-VENTED  
LOCKING LID

65 VT XLPE

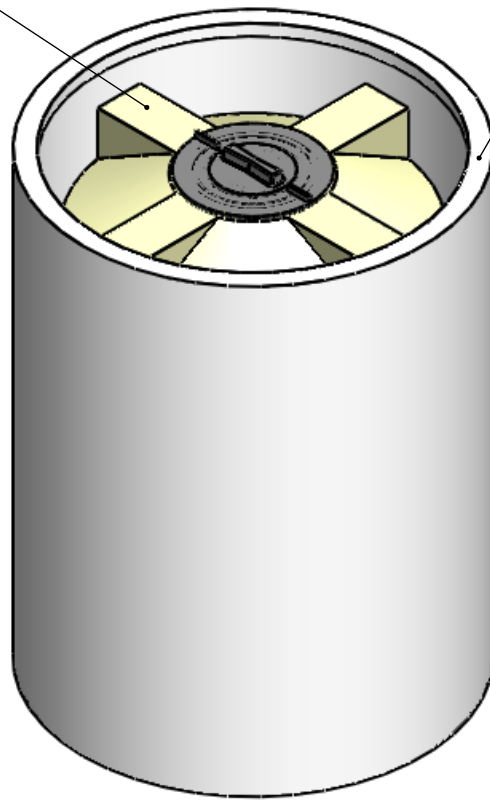

OVER PACK

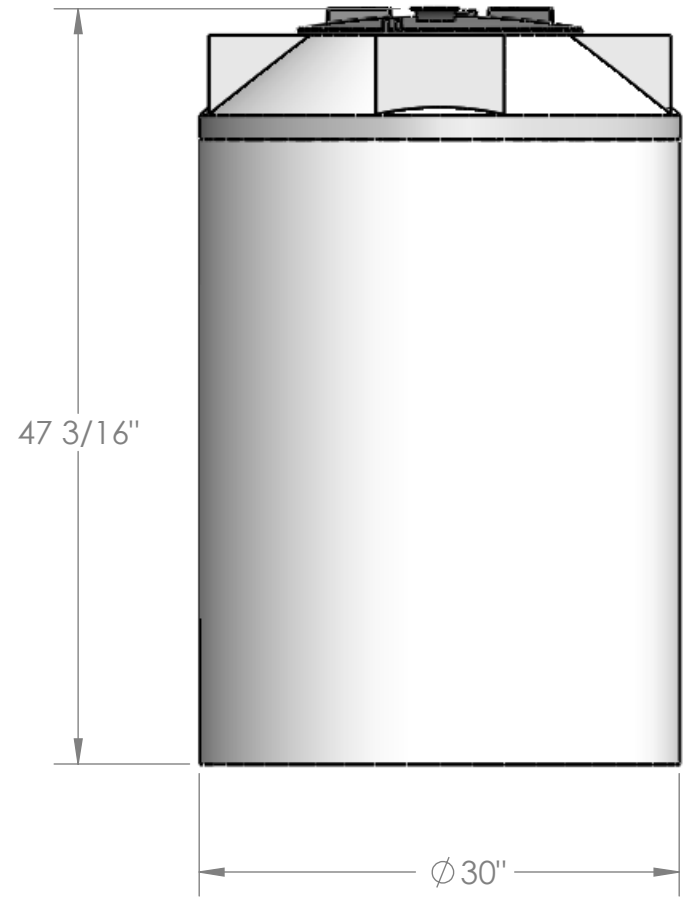
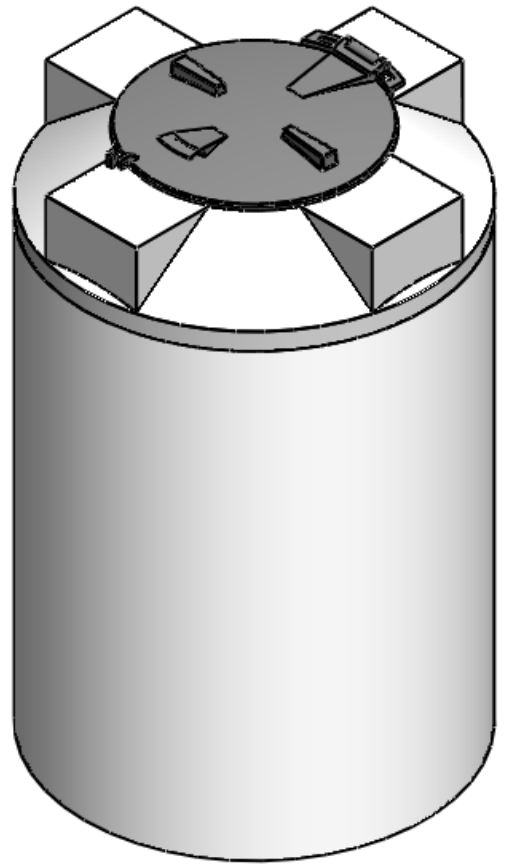

NOTES:

1. PRIMARY TANK CAPACITY: 65 GALLONS
2. OVER PACK CAPACITY: 100 GALLONS
3. MATERIAL: TANK - NAT. XLPE
4. OVERPACK: HDPE
5. SHIPPING WEIGHT: 60 LBS.

**PROPRIETARY AND CONFIDENTIAL**  
THE INFORMATION CONTAINED IN THIS DRAWING IS THE SOLE PROPERTY OF <INSERT COMPANY NAME HERE>. ANY REPRODUCTION IN PART OR AS A WHOLE WITHOUT THE WRITTEN PERMISSION OF <INSERT COMPANY NAME HERE> IS PROHIBITED.

		UNLESS OTHERWISE SPECIFIED:		NAME	DATE	CUSTOM ROTO-MOLDING, INC.		
		DIMENSIONS ARE IN INCHES TOLERANCES: FRACTIONAL ± ANGULAR: MACH ± BEND ± TWO PLACE DECIMAL ± THREE PLACE DECIMAL ±		DRAWN	1-17-12			
		INTERPRET GEOMETRIC TOLERANCING PER:		CHECKED		TITLE: <b>65 VT XL ENCAPSULATED</b>		
		MATERIAL		ENG APPR.				
		FINISH		MFG APPR.				
NEXT ASSY	USED ON			Q.A.		SIZE	DWG. NO.	REV
APPLICATION		DO NOT SCALE DRAWING		COMMENTS:		<b>B</b>	<b>65 VTEXTL</b>	
						SCALE: 1:16 WEIGHT:		SHEET 1 OF 1

8 7 6 5 4 3 2 1