

DETAIL A
SCALE 1 : 8

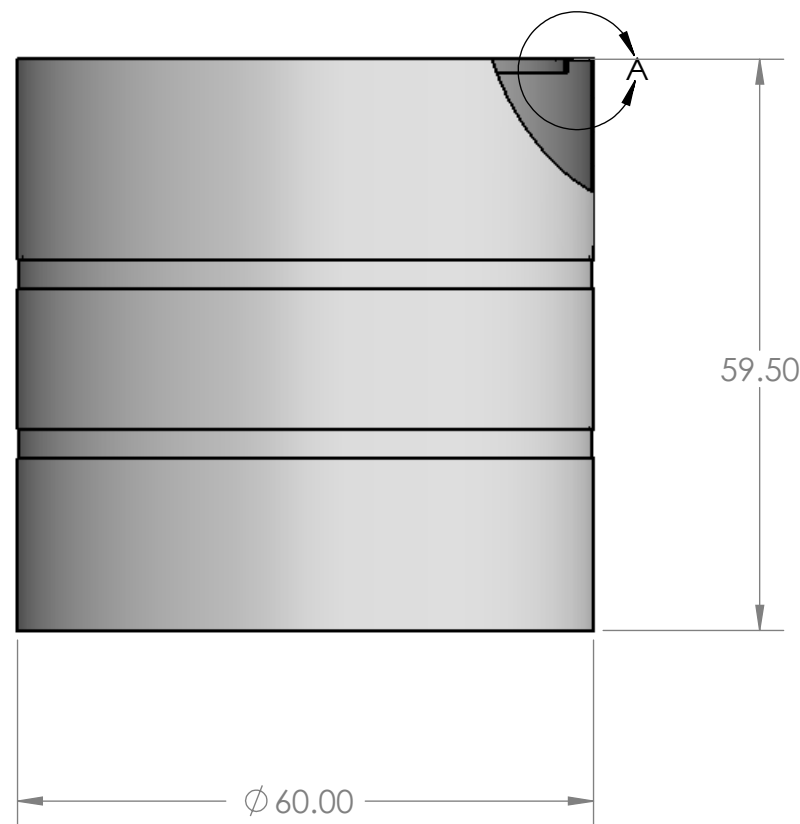
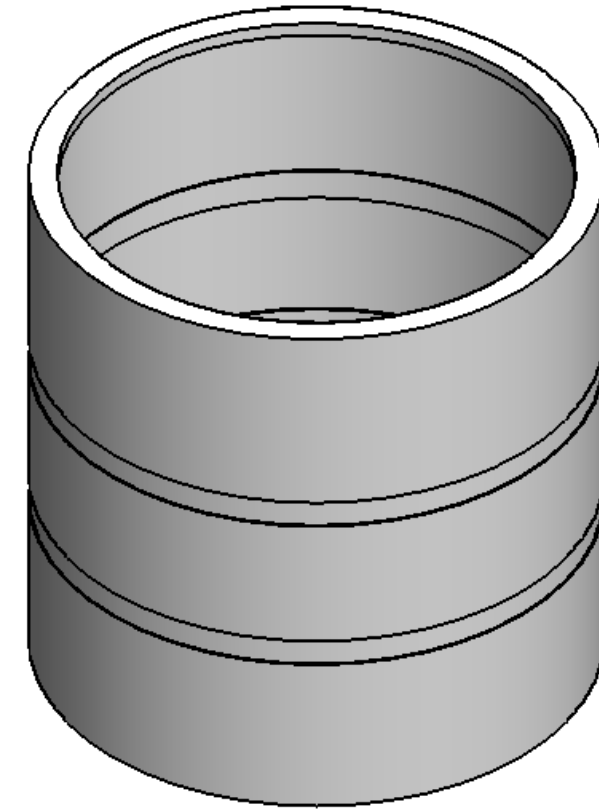

NOTES:

1. MATERIAL: HDPE
2. MOLDED WT. 120 LBS
3. RATED 1.5 S.G.

PROPRIETARY AND CONFIDENTIAL
 THE INFORMATION CONTAINED IN THIS DRAWING IS THE SOLE PROPERTY OF <INSERT COMPANY NAME HERE>. ANY REPRODUCTION IN PART OR AS A WHOLE WITHOUT THE WRITTEN PERMISSION OF <INSERT COMPANY NAME HERE> IS PROHIBITED.

		UNLESS OTHERWISE SPECIFIED:		NAME	DATE	CUSTOM ROTO-MOLDING, INC.
		DIMENSIONS ARE IN INCHES TOLERANCES: FRACTIONAL ± ANGULAR: MACH ± BEND ± TWO PLACE DECIMAL ± THREE PLACE DECIMAL ±		DRAWN	1-14-11	
		INTERPRET GEOMETRIC TOLERANCING PER:		CHECKED		TITLE:
		MATERIAL		ENG APPR.		700 GALLON OPEN TOP TANK
		FINISH		MFG APPR.		SIZE
NEXT ASSY	USED ON	DO NOT SCALE DRAWING		Q.A.		DWG. NO.
APPLICATION				COMMENTS:		B 700 OTT
						REV
						SCALE: 1:24 WEIGHT:
						SHEET 1 OF 1