

DETAIL A
SCALE 1 : 8

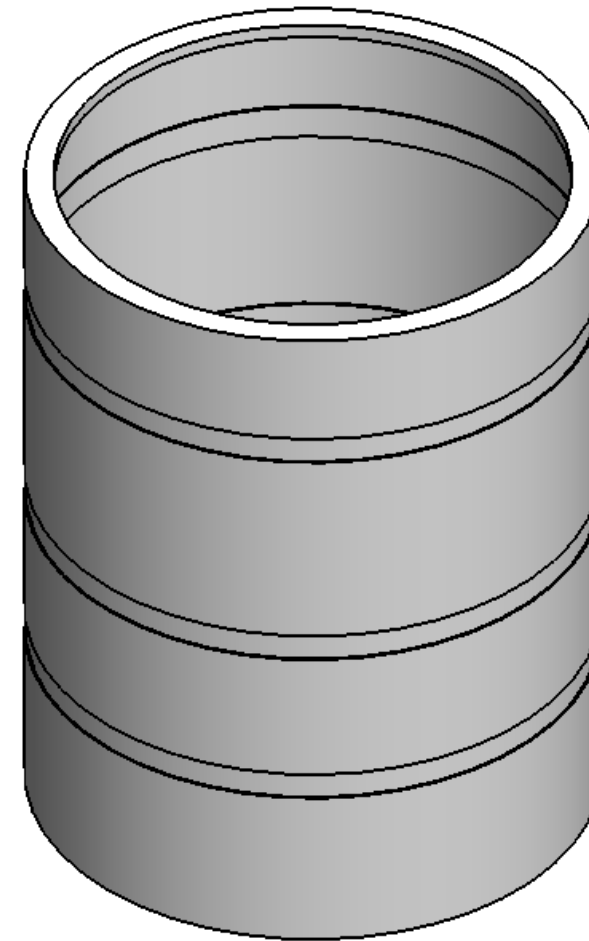

NOTES:

1. MATERIAL: HDPE
2. MOLDED WT. 175 LBS
3. RATED 1.5 S.G.

PROPRIETARY AND CONFIDENTIAL
 THE INFORMATION CONTAINED IN THIS DRAWING IS THE SOLE PROPERTY OF <INSERT COMPANY NAME HERE>. ANY REPRODUCTION IN PART OR AS A WHOLE WITHOUT THE WRITTEN PERMISSION OF <INSERT COMPANY NAME HERE> IS PROHIBITED.

		UNLESS OTHERWISE SPECIFIED:		NAME	DATE	CUSTOM ROTO-MOLDING, INC.	
		DIMENSIONS ARE IN INCHES		DRAWN	EBW	1-14-11	
		TOLERANCES:		CHECKED			TITLE:
		FRACTIONAL ±		ENG APPR.			925 GALLON OPEN TOP TANK
		ANGULAR: MACH ± BEND ±		MFG APPR.			SIZE
		TWO PLACE DECIMAL ±		Q.A.			DWG. NO.
		THREE PLACE DECIMAL ±		COMMENTS:			REV
		INTERPRET GEOMETRIC TOLERANCING PER:					B
		MATERIAL					925 OTT
NEXT ASSY	USED ON	FINISH					SCALE: 1:24
APPLICATION		DO NOT SCALE DRAWING					WEIGHT:
							SHEET 1 OF 1